



TECHNICAL SPECIFICATIONS

PERFORMANCE

Maximum working height	50'
Maximum side reach unrestricted	28' 6"
Maximum basket capacity with standard basket	441 lbs
Moveable Jib articulating range	90°
Turret rotation range	+/-356°
Maximum slope to stabilize (deployment)	17° (31%)
Height / Width tracks adjustment	31" - 46"
Maximum slope approach angle / slope	28° (53%)
Gradeability -- max. travel angle / slope*	18° (32%)
Maximum crawler travel speed**	0 - 2.2 ft/s

DIMENSIONS

Basket height (basket is removable, variations available)	43"
Basket width	27"
Basket length	48"
Total length	17' 5"
Length without basket	15'
Height in transport position	76"
Height in transport position (with tracks extended)	90"
Total width (without basket, tracks in)	32"
Total width (without basket, tracks extended)	41"
Free height from the ground	12"
Tracks (LxW)	62" x 7"
Outrigger spread length	12' 3"
Outrigger spread width	10' 2"
Outrigger foot diameter	7"

WEIGHT

Total weight	5,180 lbs
--------------------	-----------

POWER

Honda iGX390 gas engine	11.6 HP
-------------------------------	---------

*Technical specifications are non-binding, in some cases are approximate, and are subject to change.

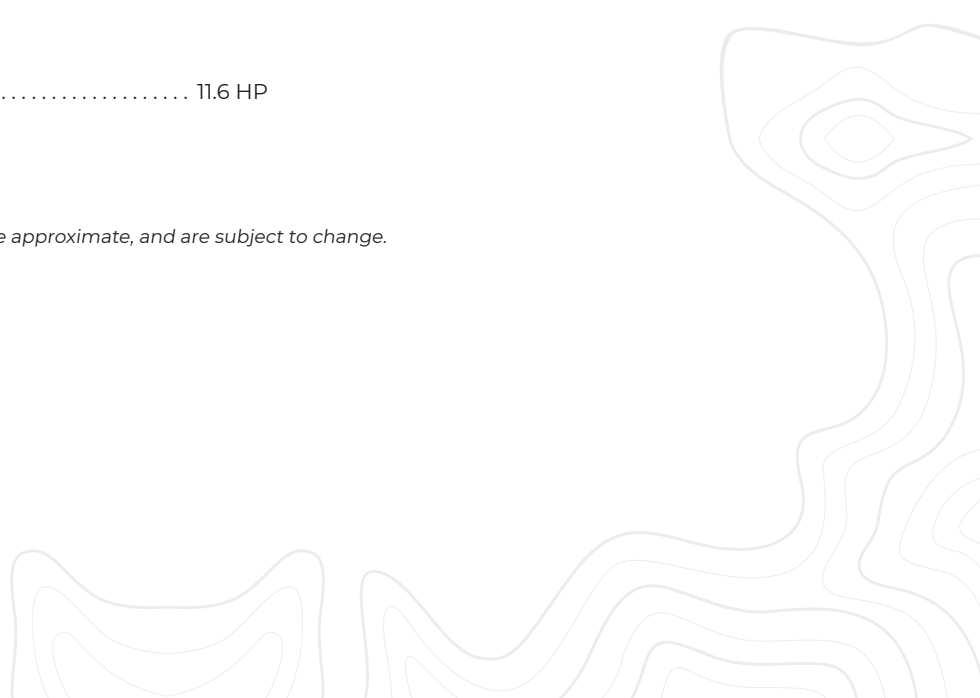



DIAGRAMS

*Measurements are in feet and inches

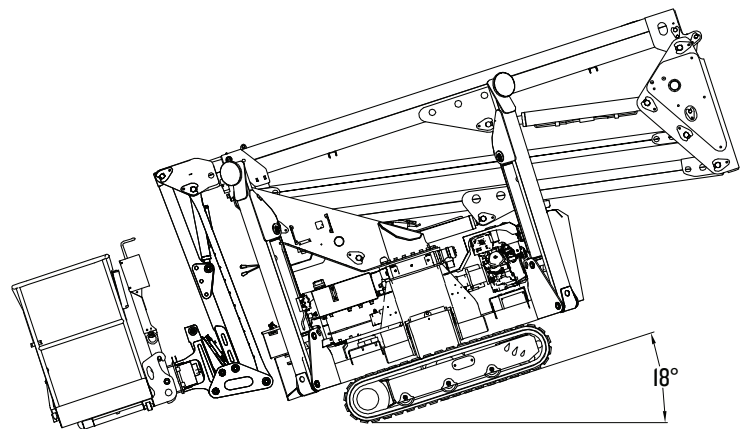
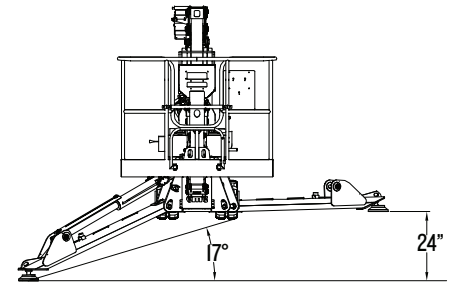
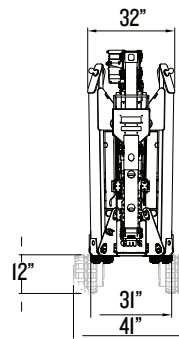
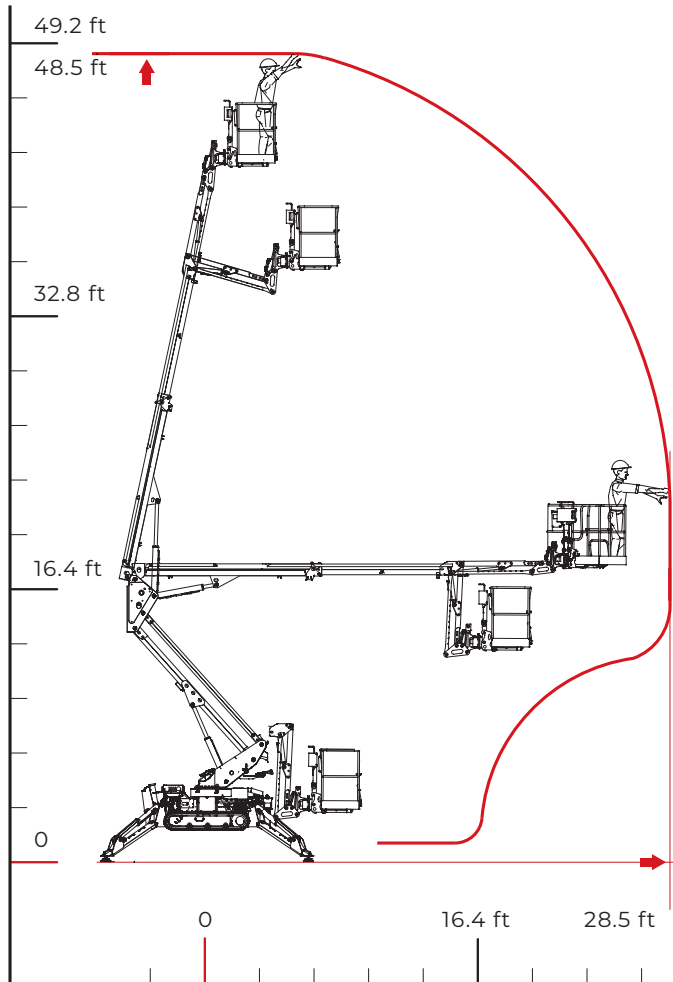
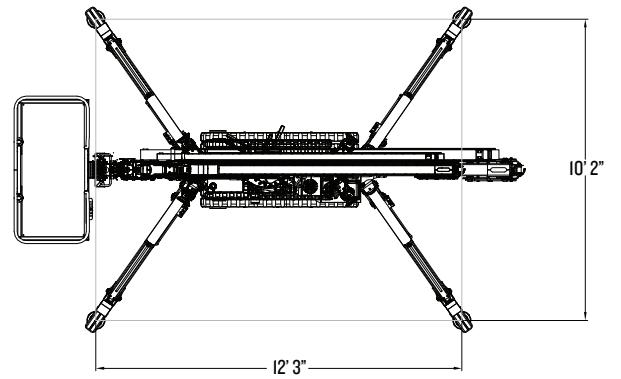
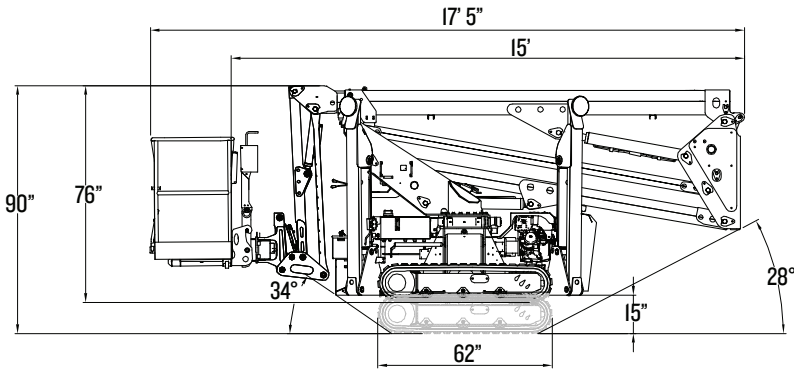

*Technical specifications are non-binding, in some cases are approximate, and are subject to change.